



Pneumatic Agitator A MAN R PR SE2

Operation manual

MAG00007EN, V01

N6804...

Information about the document

This document describes the correct handling of the product.

- Read the document prior to every activity.
- Prepare the document for the application.
- Pass on the product only together with the complete documentation.
- Always follow safety instructions, handling instructions and specifications of every kind.
- Illustrations can deviate from the technical construction.

Validity range of the document

This document describes the products with the following material numbers:

N68040616 AGITATOR A MAN R PR 75 330 SE2	
N68040617 AGITATOR A MAN R PR 75 369 SE2	
N68040618 AGITATOR A MAN R PR 75 440 SE2	
N68040619 AGITATOR A MAN R PR 75 550 SE2	
N68040620 AGITATOR A MAN R PR 75 650 SE2	
N68040621 AGITATOR A MAN R PR 100 330 SE2	
N68040622 AGITATOR A MAN R PR 100 440 SE2	
N68040623 AGITATOR A MAN R PR 100 550 SE2	
N68040624 AGITATOR A MAN R PR 100 650 SE2	
N68040625 AGITATOR A MAN R PR 75 440 OL SE2	

Hotline and Contact

If you have queries or would like technical information, please contact your dealer or sales partner.

TABLE OF CONTENTS

1	Product overview	4		
	1.1 Overview.....	4		
	1.2 Short description.....	4		
2	Safety	4		
	2.1 Presentation of Notes.....	4		
	2.2 Intended Use.....	4		
	2.3 Residual risks.....	6		
	2.4 Property damage.....	6		
	2.5 Conduct in the event of a hazardous situation.....	7		
	2.6 Staff qualification.....	7		
	2.7 Personal protective equipment.....	7		
3	Design and Function	8		
4	Transport, scope of supply and storage	8		
	4.1 Unpacking.....	8		
	4.2 Transport.....	8		
	4.3 Scope of delivery.....	9		
	4.4 Storage.....	9		
5	Assembly	9		
	5.1 Assembly.....	9		
	5.2 Ground agitator.....	10		
	5.3 Assemble the compressed air hose.....	10		
6	Operation	11		
	6.1 Safety recommendations.....	11		
	6.2 General notes.....	12		
	6.3 Checks.....	12		
	6.4 Agitate.....	13		
7	Cleaning	14		
	7.1 Safety recommendations	14		
	7.2 Overview.....	15		
	7.3 Manual cleaning.....	15		
	7.4 Cleaning container.....	15		
	7.5 Cleaning bath.....	16		
8	Maintenance	17		
	8.1 Safety recommendations.....	17		
	8.2 Maintenance schedule.....	18		
	8.3 Lubrication schedule.....	18		
	8.4 Lubrication.....	18		
9	Faults	19		
	9.1 Safety recommendations	19		
	9.2 Behavior during faults.....	20		
	9.3 Defects table.....	20		
	9.4 Troubleshooting.....	21		
	9.4.1 Replace agitator blade.....	21		
	9.4.2 Replace agitator shaft.....	21		
	9.4.3 Replace throttle valve.....	22		
	9.4.4 Replace pneumatic motor.....	23		
	9.5 After troubleshooting.....	23		
10	Disassembly and Disposal	23		
	10.1 Safety recommendations.....	23		
	10.2 Disassemble compressed air hose.....	24		
	10.3 Disassemble ground conductor.....	24		
	10.4 Disposal	24		
11	Technical data	25		
	11.1 Dimensions and weight.....	25		
	11.2 Connections.....	25		
	11.3 Operating conditions.....	25		
	11.4 Emissions.....	25		
	11.5 Operating values.....	25		
	11.6 Compressed air quality.....	26		
	11.7 Type plate.....	26		
	11.8 Materials used.....	26		
	11.9 Operating and auxiliary materials.....	26		
	11.10 Material specification.....	26		
12	Spare parts, tools and accessories	27		
	12.1 Spare parts.....	27		
	12.2 Accessories.....	28		
	12.3 Order.....	28		
13	Index	29		

1 Product overview

1.1 Overview

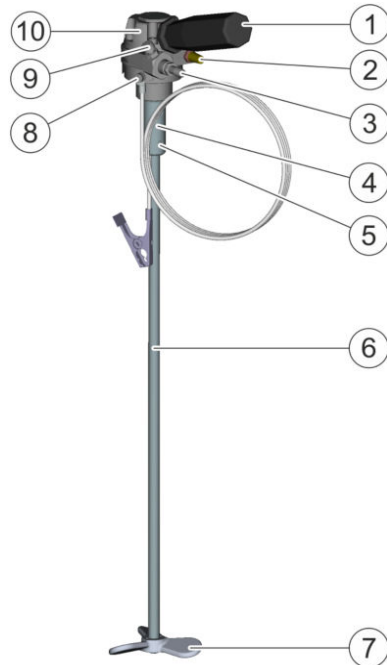

Fig. 1: Overview

- 1 Handle
- 2 Sound muffler
- 3 Compressed air supply connection
- 4 Connecting piece
- 5 Threaded pin
- 6 Agitator shaft
- 7 Agitator
- 8 Grounding screw with ground conductor
- 9 Throttle valve on/off
- 10 Pneumatic motor

1.2 Short description

The pneumatic agitator (hereafter called “agitator”) is used for agitating, mixing and consistency maintenance of fluid coating materials.

2 Safety

2.1 Presentation of Notes

The following notes can appear in this instruction:

⚠ DANGER!

High risk situation that can lead to serious injuries or death.

⚠ WARNING!

Medium risk situation that can lead to serious injuries or death.

⚠ CAUTION!

Low risk situations that can lead to minor injuries.

! NOTICE!

Situations that can lead to material damage.

🌱 ENVIRONMENT!

Situations that can lead to environmental damage.



Additional information and recommendations.

2.2 Intended Use

Use

The agitator A MAN R with pneumatic motor is to be used exclusively for agitating, mixing and consistency maintenance of fluid coating materials in open containers. The agitator may exclusively be used in original packs and with suitable approved cleaning agents.

The agitator may only be operated within the approved technical data ↪ 11 “Technical data”.

The agitator is intended for use in industry and trade only.

The agitator may be used under the following conditions:

- In explosive areas of Ex zones 1 and 2
- In non-explosive areas
- With flammable fluid coating materials of the Explosion group IIA
- With non-flammable fluid coating materials
- In suitable original containers
- Coating materials and original containers are conductive und grounded.
- Only use agitator in a container pointed downwards.
- The pneumatic motor is always positioned 200mm above the container.

Misuse

Not using as intended entails danger to life.

Examples of wrong use are:

- Processing of gaseous or solid materials
- Use of components that are not approved by Dürr Systems for operation.
- Use of unapproved materials, see safety data sheets
- Making conversions or changes on your own
- Use of the agitator in Ex zone 0
- Operation of the agitator without liquid coating materials
- Use in passing through operation
- Use of the agitator without connection to the potential equalization
- Use in non-conductive containers

Passing through operation

The agitator is not designed for pass-through operation.

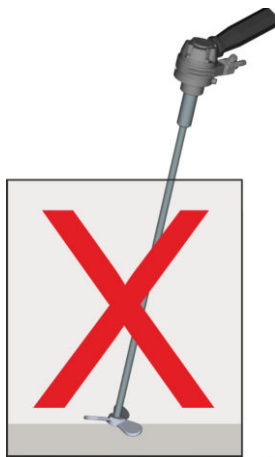

Fig. 2: Passing through operation

The operation during the passing through operation is not permitted. During passing through operation, the agitator blade is not completely immersed into the fluid.

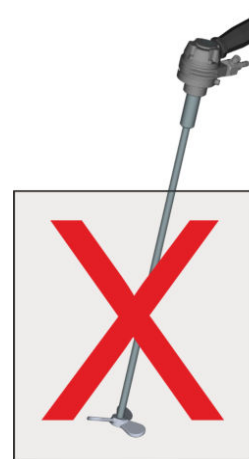

Fig. 3: Operation during idle run

The operation without fluid is not permitted.

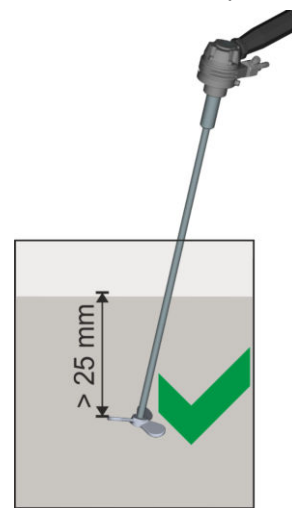

Fig. 4: Approved operation

The agitator blade is completely immersed into the fluid. The distance of the agitator blade to the surface of the fluid is at least 25mm.

Ex labeling

⊕ II 2G Ex h IIA T4 Gb X

- II - Device group II: all areas except mining
- 2G - Device category 2 for gaseous ex-atmosphere
- h - Ignition protection category
- IIA - Explosion group
- T4 - Temperature class
- Gb - Device protection level EPL
- X - Restriction: The device is configured for operation in an ambient temperature of 0°C to 40°C.

2.3 Residual risks

Danger of fire and explosion

Sparks, open flames and hot surfaces can cause explosions in explosive atmospheres. Serious injury and death could be the consequence.

- Before carrying out any work, make sure that there is no explosive atmosphere.
- Do not use sources of ignition and open light.
- Do not smoke.
- Ground Agitator.
- Wear suitable protective equipment.

Flammable coating materials and their detergents and cleaning agents can cause a fire or an explosion.

- Ensure that the flashpoint of the cleaning agent is at least 15K above the ambient temperature or clean Agitator at the cleaning areas with active technical ventilation, in painting booths, according to EN 16985.
- Observe explosion group of the coating materials and their detergents and cleaning agents.
- Follow the safety data sheet.
- Ensure that technical ventilation and fire protection equipment are in operation.
- Do not use sources of ignition and open light.
- Do not smoke.
- Ground Agitator.
- Wear suitable protective equipment.

Material

Serious injuries or death can result if you come into contact with dangerous fluids or steam.

- Ensure that the forced ventilation is operational.
- Follow the safety data sheet.
- Adjust the rotational speed to the material viscosity.
- Avoid eddy formation.
- Reduce rotational speed when removing material.
- Keep the agitator at a safe distance from the wall and the bottom of the container.
- Wear specified protective equipment.

Noise

The sound pressure level during operation may cause severe hearing damage.

- Wear ear protection.
- Do not spend more time than necessary in the work area.

Rotary components

Clothing or hair can get entangled in the rotary components and if body parts come in contact with them, it can result in serious injuries.

To avoid injuries:

- Keep the product at a safe distance from the body.
- Do not touch rotary components.
- Wear close-fitting work clothes.
- If you have long hair, wear a head cover.
- Wear specified protective equipment.

Compressed air

Hoses under pressure can tear or burst. Escaping compressed air can cause serious injury.

- Protect compressed air hoses from heat and sharp edges.
- Do not let the compressed air hose bear the weight of the agitator.
- Do not use the compressed air hose to pull the throttle valve.
- Separate the agitator from the compressed air supply after the end of working hours.
- Wear specified protective equipment.

If hoses under pressure come off loose, the hoses can lash around and cause injuries.

- Check that the hose connections are seated tightly.
- Check compressed air hoses for damage.
- Relieve pressure from the hoses after each operation end and before servicing and maintenance work.

2.4 Property damage

Rotational speed too high

Operating the agitator at excessively high rotational speeds causes eddy currents and mixes-in air. Air in the material line can cause uneven coating.

- Adjust the rotational speed to the material viscosity.
- Reduce rotational speed when removing material

Passing through operation

If the agitator blade is not completely immersed into the fluid during operation, vibrations occur at the agitator shaft. This could cause damages to the agitator and the container.

- Immerse agitator blade at least 25mm into the fluid.

Unprepared material

If you do not agitate the material well, the settled material particles remain at the bottom of the container. This can cause imperfect painting results.

- Agitate the material in the delivery pack before painting or emptying.

2.5 Conduct in the event of a hazardous situation

Conduct in case of danger depends on the operator's installation situation.

Perform the following activities:

- Close lines.
- Secure against reconnection.
- Depressurize lines.

2.6 Staff qualification



WARNING!

Inadequate qualification

Wrong estimation of dangers can cause serious injury or death.

- Only sufficiently qualified persons may execute all work.
- Some work requires additional qualification. Additional qualifications of specialized personnel are marked with a "+".

This document is intended for qualified personnel in industry and craftsmanship.

Cleaning staff

The cleaning staff receives regular instructions from the operator about the following contents:

- Using the product
- Handling cleaning tools
- Handling cleaning agents
- Technical Measures for occupational safety and health

Electrician

Electricians assemble, install, service and repair electrical systems in a professional manner.

Furthermore, electrical engineers have the following knowledge:

- Directives, Standards and Rules of Engineering
- Local conditions
- Electrical Systems and Their Loading Limits
- Technical Measures for occupational safety and health

Mechanic

The mechanic is trained specifically for the field of work in which he works.

Furthermore, he has the following knowledge:

- Directives, Standards and Rules of Engineering
- Local conditions
- Technical Measures for occupational safety and health

The mechanic is responsible for the following activities on equipment and components:

- Assembly
- Waiting
- Maintenance
- Disassembly

Operator

The operator is trained specifically for the field of work in which he works.

Furthermore, the operator possesses the following knowledge:

- Technical Measures for occupational safety and health

The operator is responsible for the following work:

- Operate and monitor the system/ product.
- Introduce measures in the event of faults.
- Clean system/ product.

+ additional qualification explosion protection

In addition to the knowledge of the various specialist fields, the mechanic has knowledge of regulations and safety measures when working in potentially explosive areas.

Dürr Systems offers special product training for "Hotline and Contact".

2.7 Personal protective equipment

When working in explosive areas, the protective clothing, including gloves, must meet the requirements of EN 1149-5. Footwear must meet the requirements of ISO 20344 and IEC 61340-4-3. The volume resistivity must not exceed 100MΩ.

Wear the specified personal protective equipment when working. Provide the following personal protective equipment:



Anti-Static Safety Boots

Protect feet from crushing, falling items and slipping on slippery ground.

Moreover, anti-static safety boots reduce electrostatic charge by discharging the electrostatic charges.



Eye protection

Protects eyes from dust, paint drops and particles.



Protective gloves

Protect the hands from:

- mechanical forces
- Thermal forces
- Chemical effects



Protective workwear

Tight fitting workwear with low tear strength, tight sleeves and no hanging parts.



Respiratory protection device

The respiratory protection device protects from hazardous gases, vapors, dust and similar materials and media. The version of the respiratory protection device must be suitable for the media used as well as their usage.



Safety boots

Protect feet from crushing, falling items and slipping.



Use ear protection

Protects from auditory damage due to noise.

3 Design and Function

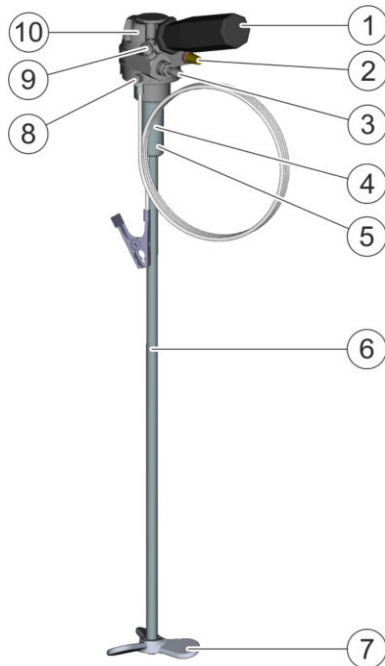

Fig. 5: Construction and function

- 1 Handle
- 2 Sound muffler
- 3 Compressed air supply connection
- 4 Connecting piece
- 5 Threaded pin
- 6 Agitator shaft
- 7 Agitator
- 8 Grounding screw with ground conductor
- 9 Throttle valve on/off
- 10 Pneumatic motor

For agitating material, you can hold the agitator by its handle (1) or mount it in a stand. The agitator is connected to the compressed air by the connection (3). The agitator is switched on and off at the throttle valve (9) and the rotation speed of the agitator shaft (6) is set. The pneumatic motor (10) drives the agitator shaft via the connecting piece (4). The agitator blade (7) is firmly connected to the agitator shaft and rotates synchronously with it. The sound muffler (2) at the outlet of the pneumatic motor reduces sound emission.

4 Transport, scope of supply and storage

4.1 Unpacking



Electrostatically charged plastic films and foils in potentially explosive areas

The foil and the product can charge electrostatically at the time of the unpacking. Electrostatic discharge can cause sparks that in explosive atmosphere can cause a fire or an explosion. Serious injury and death could be the consequence.

- Unpack product outside Ex zones.
- Discharge the product.
- Dispose packaging outside of the Ex zone in accordance with the regulation or store properly for a later return.



Incorrect disposal

Incorrectly disposed packaging material can damage environment.

- Dispose of material no longer required in an environment-friendly manner.
- Observe local disposal specifications.

4.2 Transport



Incorrect Transport

Improper transport of the agitator may cause the agitator to fall and suffer damage.

- Protect agitator from moisture.
- Protect the agitator from vibrations.
- Ensure that the transport ways a free from obstructions.

4.3 Scope of delivery

The scope of supply includes the following components:

- Agitator
- Ground conductor
 - ↳ 12.2 “Accessories”

Inspect delivery on receipt for completeness and integrity.

Report defects immediately ↳ “Hotline and Contact”.

4.4 Storage

Storage provisions:

- Do not store outdoors.
- Store Agitator only when dry.
- Store in a dust-free place.
- Do not expose to aggressive media.
- Protect from solar radiation.
- Avoid mechanical vibrations.
- Temperature: 10°C to 40°C
- Relative humidity: 35% to 90%
- Protect agitator shaft and agitator blade from load to avoid bending.

5 Assembly

5.1 Assembly

Mount agitator on a stand

As an option, you can mount the agitator on a stand.

 Dürr Systems recommends the use of the stand to avoid any contact of the agitator with the container. The stand is not part of the basic version. The stand can be ordered separately ↳ 12.2 “Accessories”.

Personnel:

- Mechanic

Protective equipment:

- Safety boots

Requirements:

- Agitator is switched off ↳ 6.4 “Agitate”.

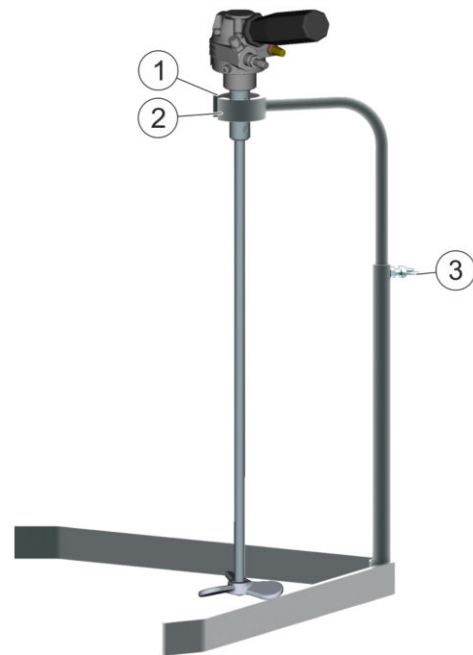

Fig. 6: Mount agitator on a stand

1. Insert the agitator in the clamp (2) of the stand.
2. Tighten the butterfly screw (1).
⇒ Agitator is fastened.
3. Adjust its height on the mast by using the butterfly screw (3).

5.2 Ground agitator

EX WARNING!

Sparks due to electrostatic discharge

If the agitator is not grounded, there can be an electrostatic charge on the the agitator. Electrostatic discharge can cause sparks that in explosive atmosphere can cause a fire or an explosion. Serious injury and death could be the consequence.

- Ground Agitator as specified.
- Before carrying out any work, make sure that there is no explosive atmosphere.

Personnel:

- Electrician
- + additional qualification explosion protection

Protective equipment:

- Anti-Static Safety Boots

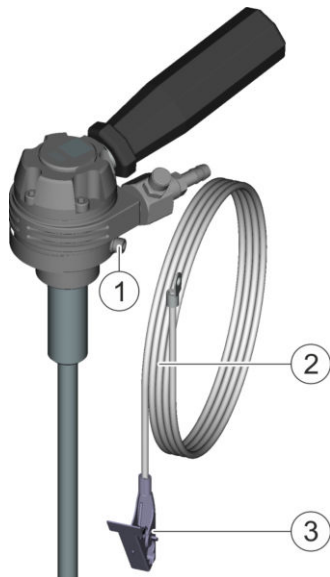

Fig. 7: Grounding

1. Connect ground cable (2) to the grounding connection (1) on the pneumatic motor.
2. Connect the terminal (3) of the ground conductor to a secure current conductor.
3. Measure grounding resistance ↪ 11.5 “Operating values”.



Container for the material must be grounded.

5.3 Assemble the compressed air hose

! NOTICE!

Foreign bodies in the compressed air hose

If there are foreign bodies in the compressed air hose, the motor is blocked.

- Before initial commissioning or after a modification, blow out the compressed air hose before the pneumatic motor is connected.
- When assembling the compressed air hose, ensure that no foreign bodies enter the compressed air hose.
- Observe compressed air quality ↪ 11.6 “Compressed air quality”.

Personnel:

- Mechanic
- + additional qualification explosion protection

Protective equipment:

- Eye protection
- Protective gloves
- Safety boots

Materials:

- suitable compressed air hose
- Observe the maximum operating pressure ↪ 11.5 “Operating values”.

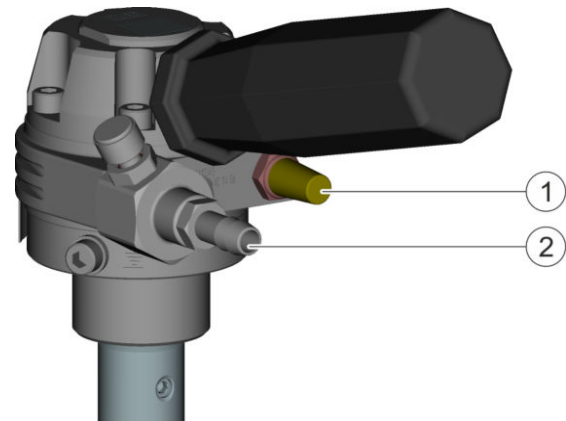



Fig. 8: Assemble the compressed air hose

1. **! NOTICE!**

Rust protector or oil in the pneumatic motor can clog the sound muffler. The result is a performance drop in the pneumatic motor.

Remove sound muffler (1).

2. Spray some oil into the connection for the compressed air supply (2) ↪ 11.9 “Operating and auxiliary materials”.

 The oil prevents the pneumatic motor from running dry during the initial warm-up.

3. Raise compressed air hose onto the connection (2).
4. Secure compressed air hose with a hose clamp to prevent slipping.
5. Connect the other end of the compressed air hose to the compressed air supply.
6. Let the pneumatic motor run briefly without the sound muffler (1).
 - ⇒ Residue in the pneumatic motor (e.g. rust protection or oil) will be removed.
7. Assemble the sound muffler (1).

6 Operation

6.1 Safety recommendations

 **WARNING!**

Danger of explosion due to sources of ignition in an explosive atmosphere.

Sparks, open flames and hot surfaces can cause explosions in explosive atmospheres. Serious injury and death could be the consequence.

- Do not use any sources of ignition and no open light in the work area.
- Do not smoke.
- Check grounding.
- Wear suitable protective equipment.
- Observe the explosion group of the medium.

 **WARNING!**

Danger of explosion due to sources of ignition in an explosive atmosphere.

If a rotary component of the agitator touches a fixed object, it can generate sparks. Sparks can cause explosions in explosive atmospheres. Serious injury and death could be the consequence.

- The agitator may only be used in the delivery pack.
- Make sure that there are no objects present in the container.
- Maintain minimum distances to the container.

 **WARNING!**

Danger from harmful or irritant substances

Serious injuries or death can result if you come into contact with dangerous fluids or steam.

- Agitator Check regularly for leakage. Observe local regulations and maintenance schedule.
- Ensure that the forced ventilation is operational.
- Follow the relevant safety data sheets.
- Wear specified protective equipment.
- Avoid contact (e.g. with eyes, skin).

 **WARNING!**

Danger due to rotary components

If using the agitator outside a closed container, clothing or hair can get entangled in the rotary components and if body parts come in contact with them, it can result in serious laceration and amputation.

- The agitator may only be used in a closed container.

 **WARNING!**

Hoses whipping around

If hoses under pressure come off loose, the hoses can lash around and cause injuries.

- Check that the hose connections are seated tightly.
- Check hoses for damage.
- Do not reach for lashing hoses.
- Before carrying out any work:
 - Disconnect the compressed air supply and secure it personalized from being switched on again.
 - Depressurize hoses.

 **WARNING!**

Escaping compressed air

Compressed air hoses may rupture if under pressure. Escaping compressed air can cause serious injury.

- Disconnect the product from the compressed air supply after the end of working hours.
- Observe the service life of the compressed air hoses. Replace outdated compressed air hoses.

! WARNING!

Danger due to escaping compressed air

Compressed air escaping from the sound muffler can contain solid or liquid particles. Particles under pressure can injure the eyes or the skin.

- Wear specified protective equipment.

! WARNING!

Danger due to damaged components

Operating the product with damaged components can result in serious injury or death.

- Check components at specified intervals for damage.
- If you detect unusual operating sounds or any other noticeable aspects, put the product out of service.
- Contact the manufacturer ↪ “Hotline and Contact”.
- Replace damaged components promptly.

6.2 General notes

! NOTICE!

Contact of rotating components with objects

If the rotary agitator touches a fixed object, the agitator shaft can bend or the agitator blade can be damaged.

A bent agitator shaft can cause high vibrations in the pneumatic motor. The vibrations can make the agitator to come loose from the stand and touch the walls or bottom of the container. Material can squirt out.

Contact with objects can reduce the service life of the components.

- Keep agitator at a safe distance from the wall and the bottom of the container.
- Keep agitator at a safe distance from objects.

! NOTICE!

Risk of corrosion

If the agitator is operated with oil-free and moist compressed air, there is risk of corrosion to the pneumatic motor and motor standstill.

- Observe specifications about compressed air quality ↪ 11.6 “Compressed air quality”.
- Maintain recommended rotational speed range ↪ 11.5 “Operating values”.

! NOTICE!

Unprepared material

If you do not agitate the material well, the settled material particles remain at the bottom of the container. This can cause imperfect painting results.

- Agitate the material before painting or emptying.

! NOTICE!

High rotational speed

Operating the agitator at excessively high rotational speeds causes eddy currents and mixes-in air. Air in the material line can cause uneven coating.

- Adjust the rotational speed to the material viscosity.
- Reduce rotational speed when removing material

! NOTICE!

Operation without medium

Operating the agitator in an empty container or in air may damage the agitator shaft.

Operate the agitator in a medium only.

6.3 Checks



Check condition of the agitator prior to the start of the shift. If there are abnormalities (i.e. unusual noises, vibrations, damage, defective operation), stop the agitator immediately and repair it.

Perform the following checks before beginning the shift:

- Cleanliness
Ensure there are no material residues and other contaminants. Damage and leaks can only be seen on clean components.
- Check tightness of the connections and lines.
- Threaded pin on the connecting piece is tightened.
- Screw on the agitator blade is tightened.
- A pin is present in the agitator blade.
- Material temperature ↪ 11.3 “Operating conditions”
- Operating pressure ↪ 11.5 “Operating values”
- Ground conductor is correctly connected ↪ 5.2 “Ground agitator”.
- Grounding screw is tightened ↪ 5.2 “Ground agitator”.

6.4 Agitate

! NOTICE!

Unprepared material

If you do not agitate the material well, the settled material particles remain at the bottom of the container. This can cause imperfect painting results.

- Agitate the material before painting or emptying.

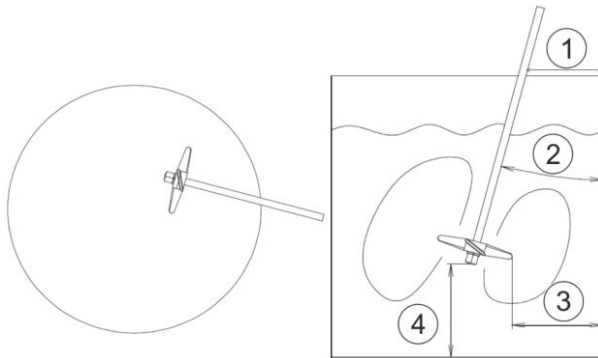

Fig. 9: Ideal agitating position (without stand)

- 1 Distance from the wall, 25mm
- 2 Agitating angle, approx. 15°
- 3 Distance from the wall, min. 25mm
- 4 Distance from the floor, min. 25mm

Personnel:

- Operator
- + additional qualification explosion protection

Protective equipment:

- Eye protection
- Respiratory protection device
- Use ear protection
- Protective gloves
- Protective workwear
- Safety boots

Requirements:

- Compressed air supply is switched on.
- Material is in the container.
- Agitator and container are grounded.
- Agitator is correctly mounted ↪ 5 "Assembly".

1.

- If you use a stand, clamp the agitator vertically.

Hold the agitator by the handle and dip it into the container outside the center (1).

Switching on

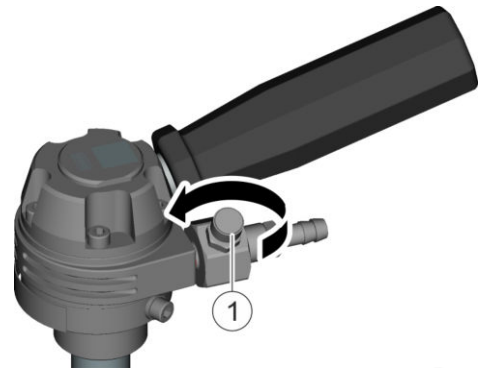

Fig. 10: Switching on

2. Slowly rotate the adjusting screw (1) on the throttle valve in the direction of the arrow.
⇒ Agitator is switched on. The more the throttle valve is opened, the faster does the agitator shaft rotate.

The rotational speed depends on the material viscosity.

3. **! NOTICE!**

High rotational speed

Operating the agitator at excessively high rotational speeds causes eddy currents and mixes-in air. Air in the material line can cause uneven coating.

- Adjust the rotational speed to the material viscosity.
- Reduce rotational speed when removing material

Rotate the adjusting screw (1) further open to increase the rotational speed.

⇒ Slight movement is visible at the surface.

Switching off

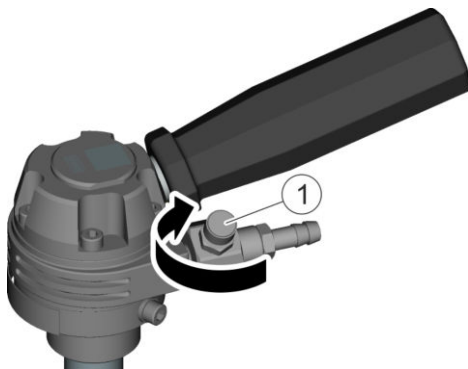

Fig. 11: Switching off

4. Rotate the adjusting screw (1) on the throttle valve in the direction of the arrow for closing.
 - ⇒ The more the throttle valve is closed, the slower does the agitator shaft rotate. If the throttle valve is closed completely, the agitator is switched off.
5. Pull out the agitator from the container.
6. Wipe material drops with a cloth.

7 Cleaning

7.1 Safety recommendations

EX WARNING!

Danger of fire and explosion

Flammable coating materials and their detergents and cleaning agents can cause a fire or an explosion.

- Do not conduct cleaning work in an explosive atmosphere.
- Ensure that the flashpoint of the cleaning agent is at least 15K above the ambient temperature or clean Agitator at the cleaning areas with active technical ventilation, in painting booths, according to EN 16985.
- Note explosion group of the fluid.
- Only use approved cleaning agents.
- Follow the safety data sheet.
- Ensure that forced ventilation and fire protection equipment are in operation.
- Do not use sources of ignition and open light.
- Do not smoke.
- After completing the cleaning work, remove cleaning agents and cleaning tools from the danger zone.

! WARNING!

Escaping material and compressed air

Escaping material under pressure can cause serious injuries.

Before carrying out any work:

- Disconnect the system, in which the agitator is installed, from compressed air and material supply.
- Secure system personalized from being switched on again.
- Depressurize the lines.

! WARNING!

Danger from harmful or irritant substances

Serious injuries or death can result if you come into contact with dangerous fluids or steam.

- Agitator Check regularly for leakage. Observe local regulations and maintenance schedule.
- Ensure that the forced ventilation is operational.
- Follow the relevant safety data sheets.
- Wear specified protective equipment.
- Avoid contact (e.g. with eyes, skin).

 **WARNING!**
Danger of fire and explosion

Electrostatic charges on the protective device pose an ignition hazard.

- Clean protective device with moist cloth only.
- Do not use dry cloth for drying.

 **NOTICE!**
Unsuitable cleaning agents

Unsuitable cleaning agents can damage the product.

- Only use cleaning agents approved by the material manufacturer.
- Follow safety data sheets.
- Place heavily soiled components in a cleaning bath.
 - Only place those parts in the cleaning bath, which are suitable for the cleaning bath.
 - Use only electrically conductive containers.
 - Ground the container.
 - Do not use ultrasound baths.

7.2 Overview

Clean agitator:

- Before every change of material
- After end of operation

Depending on the level of contamination, Dürr Systems recommends the following cleaning methods:

- Manual cleaning for light contamination
- Cleaning in a cleaning container for medium and light contamination
- Cleaning in a cleaning bath, if heavily contaminated

7.3 Manual cleaning

Clean the following components of the agitator manually for light contamination:

- Pneumatic motor
- Agitator shaft
- Agitator

Personnel:

- Cleaning staff
- + additional qualification explosion protection

Protective equipment:

- Respiratory protection device
- Eye protection
- Protective workwear
- Protective gloves
- Anti-Static Safety Boots

Requirements:

- Compressed air supply is switched off and secured against being switched on again.
- Compressed air hose is depressurized.

1. Remove contamination with a cloth or a soft brush.

7.4 Cleaning container

Clean the following components of the agitator in a cleaning tank, for medium and light contamination.

- Agitator shaft
- Agitator

Personnel:

- Cleaning staff
- + additional qualification explosion protection

Protective equipment:

- Respiratory protection device
- Eye protection
- Use ear protection
- Protective workwear
- Protective gloves
- Safety boots

Requirements:

- Compressed air supply is switched on.
- Cleaning container is unbreakable, corrosion-free and grounded.

! NOTICE!

Penetration of cleaning agents

If cleaning agents penetrates the pneumatic motor, the pneumatic motor can be damaged.

- Do not submerge pneumatic motor in the cleaning medium.

! NOTICE!

Contact of rotating components with objects

If the rotary agitator touches a fixed object, the agitator shaft can bend or the agitator blade can be damaged.

A bent agitator shaft can cause high vibrations in the pneumatic motor. The vibrations can make the agitator to come loose from the stand and touch the walls or bottom of the container. Material can squirt out.

Contact with objects can reduce the service life of the components.

- Keep agitator at a safe distance from the wall and the bottom of the container.
- Keep agitator at a safe distance from objects.

1. Hold the agitator by the handle.
2. Submerge the agitator blade and agitator shaft up to the connecting piece in the cleaning tank.

Switching on

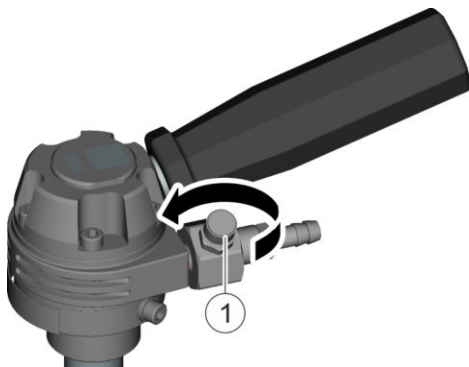

Fig. 12: Switching on

3. Slowly rotate the adjusting screw (1) in the direction of the arrow.
4. Rotate the adjusting screw (1) further open to increase the rotational speed.
5. Let it run at medium rotational speed until the contamination comes off.

Switching off

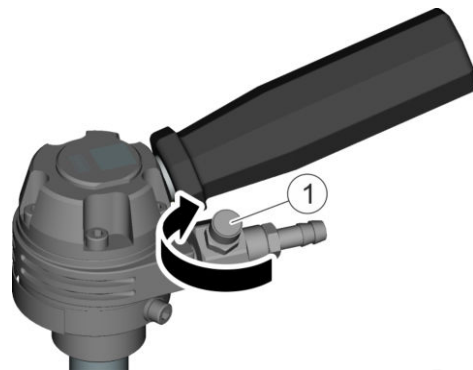

Fig. 13: Switching off

6. Rotate the adjusting screw (1) in the direction of the arrow.
 - ⇒ Agitator is switched off.
7. Pull out the agitator from the container.
8. Wipe drops with a cloth.
9. Remove loosened contaminants with a cloth or a soft brush.
 - ⇒ If necessary, repeat steps 1 to 9 until agitator is clean.
10. After cleaning, wipe the agitator dry with a cloth.

7.5 Cleaning bath

! NOTICE!

Penetration of cleaning agents

If cleaning agents penetrates the pneumatic motor, the pneumatic motor can be damaged.

- Do not submerge pneumatic motor in the cleaning medium.

Clean the following components of the agitator in a cleaning bath, if they are heavily contaminated:

- Agitator shaft
- Agitator

Personnel:

- Cleaning staff
- + additional qualification explosion protection

Protective equipment:

- Respiratory protection device
- Eye protection
- Protective workwear
- Protective gloves
- Anti-Static Safety Boots

Requirements:

- Compressed air supply is switched off and secured against being switched on again.
- Compressed air hose is depressurized.

1. Disassemble agitator blade ↪ 9.4.1 "Replace agitator blade".
2. Disassemble agitator shaft ↪ 9.4.2 "Replace agitator shaft".
3. Place components in the cleaning bath.

 The cleaning duration depends on the contamination.

4. Remove components.
5. Remove residual contamination with a soft cloth or a soft brush.
If necessary, repeat steps 3 and 4 until agitator is clean.
6. Wipe components dry with a dry clean cloth.
7. Assemble agitator shaft ↪ 9.4.2 "Replace agitator shaft".
8. Assemble agitator blade ↪ 9.4.1 "Replace agitator blade".

8 Maintenance

8.1 Safety recommendations

Do not conduct cleaning and maintenance work in explosive atmosphere.

WARNING!

Danger of fire and explosion

Flammable coating materials and their detergents and cleaning agents can cause a fire or an explosion.

- Ensure that the flashpoint of the cleaning agent is at least 15K above the ambient temperature or clean product at the cleaning areas with active technical ventilation, in painting booths, according to EN 16985.
- Note explosion group of the fluid.
- Observe the security data sheets of the media being used.
- Ensure that forced ventilation and fire protection equipment are in operation.
- Do not use sources of ignition and open light.
- Do not smoke.
- Check grounding.

WARNING!

Escaping material and compressed air

Escaping material under pressure can cause serious injuries.

Before carrying out any work:

- Disconnect the system, in which the agitator is installed, from compressed air and material supply.
- Secure system personalized from being switched on again.
- Depressurize the lines.

WARNING!

Unsuitable spare parts in explosive areas

Spare parts not compliant with the specifications of the ATEX directives can cause explosions in an explosive atmosphere. Serious injury and death could be the consequence.

- Use exclusively original spare parts.

WARNING!

Unsuitable tools in explosive areas

Tools that do not have Ex approval can generate sparks and cause a fire or an explosion in Ex zones. It can cause serious injuries or death.

- If possible, carry out cleaning and maintenance work outside the Ex zones.
- For work within the Ex zone, use tools with the corresponding Ex labeling.

EX WARNING!

Danger of explosion due to sources of ignition in an explosive atmosphere.

Metal parts falling into the container can cause sparking. Sparks can cause explosions in explosive atmospheres. Serious injury and death could be the consequence.

- Perform maintenance work outside the reach of the container.
- Prevent metal parts from falling into the container.
- After completing the maintenance work, tools from the danger zone.

! WARNING!

Components flying about

The components in the pneumatic motor are under pressure and can cause serious injuries on dismantling the pneumatic motor.

- Do not dismantle pneumatic motor.
- If there is a malfunction or fault in the pneumatic motor, please return it to the reseller.

! WARNING!

Danger from harmful or irritant substances

Serious injuries or death can result if you come into contact with dangerous fluids or steam.

- Agitator Check regularly for leakage. Observe local regulations and maintenance schedule.
- Ensure that the forced ventilation is operational.
- Follow the relevant safety data sheets.
- Wear specified protective equipment.
- Avoid contact (e.g. with eyes, skin).

8.2 Maintenance schedule

Interval	Maintenance work
Before every use	Check grounding ↪ 5.2 “Ground agitator”.
	Ensure that the screw on the agitator blade is tightened ↪ 9.4.1 “Replace agitator blade”.
	Ensure that the threaded pin on the connecting piece is tightened ↪ 9.4.2 “Replace agitator shaft”.
after each use	Clean agitator ↪ 7 “Cleaning”.

8.3 Lubrication schedule

Interval	Maintenance work
After 16 operating hours	Lubricate pneumatic motor ↪ 8.4 “Lubrication”.

8.4 Lubrication

Lubricate pneumatic motor.

If you operate the agitator with oil-free compressed air, the pneumatic motor must be lubricated manually.

Personnel:

- Mechanic

- + additional qualification explosion protection

Protective equipment:

- Protective gloves
- Anti-Static Safety Boots
- Eye protection

1. Switch off compressed air supply.
2. Depressurize the line.
3. Disconnect the compressed air hose from the compressed air supply.
4. Put in two drops of lubricant in the compressed air hose ↪ 11.9 “Operating and auxiliary materials”.

 Do not fill in the lubricant directly in the pneumatic motor.

5. Connect the compressed air hose to the compressed air supply.
6. Switch on compressed air supply.
 - ⇒ The lubricant is distributed in the pneumatic motor.

9 Faults

9.1 Safety recommendations

 **WARNING!**

Danger of fire and explosion

Flammable coating materials and their detergents and cleaning agents can cause a fire or an explosion.

- Ensure that the flashpoint of the cleaning agent is at least 15K above the ambient temperature or clean product at the cleaning areas with active technical ventilation, in painting booths, according to EN 16985.
- Note explosion group of the fluid.
- Observe the security data sheets of the media being used.
- Ensure that forced ventilation and fire protection equipment are in operation.
- Do not use sources of ignition and open light.
- Do not smoke.
- Check grounding.

 **WARNING!**

Escaping material and compressed air

Escaping material under pressure can cause serious injuries.

Before carrying out any work:

- Disconnect the system, in which the agitator is installed, from compressed air and material supply.
- Secure system personalized from being switched on again.
- Depressurize the lines.

 **WARNING!**

Unsuitable spare parts in explosive areas

Spare parts not compliant with the specifications of the ATEX directives can cause explosions in an explosive atmosphere. Serious injury and death could be the consequence.

- Use exclusively original spare parts.

 **WARNING!**

Unsuitable tools in explosive areas

Tools that do not have Ex approval can generate sparks and cause a fire or an explosion in Ex zones. It can cause serious injuries or death.

- If possible, carry out cleaning and maintenance work outside the Ex zones.
- For work within the Ex zone, use tools with the corresponding Ex labeling.

 **WARNING!**

Danger of explosion due to sources of ignition in an explosive atmosphere.

Metal parts falling into the container can cause sparking. Sparks can cause explosions in explosive atmospheres. Serious injury and death could be the consequence.

- Perform maintenance work outside the reach of the container.
- Prevent metal parts from falling into the container.
- After completing the maintenance work, tools from the danger zone.

 **WARNING!**

Danger from harmful or irritant substances

Serious injuries or death can result if you come into contact with dangerous fluids or steam.

- Agitator Check regularly for leakage. Observe local regulations and maintenance schedule.
- Ensure that the forced ventilation is operational.
- Follow the relevant safety data sheets.
- Wear specified protective equipment.
- Avoid contact (e.g. with eyes, skin).

WARNING!
Components flying about

The components in the pneumatic motor are under pressure and can cause serious injuries on dismantling the pneumatic motor.

- Do not dismantle pneumatic motor.
- If there is a malfunction or fault in the pneumatic motor, please return it to the reseller.

9.2 Behavior during faults

If faults occur:

- Switch off compressed air supply. Secure against reconnection.
- Depressurize lines.
- Follow the defects table to correct the fault.
- Carry out repairs according to IEC 60079-19.

9.3 Defects table

Fault description	Cause	Remedy
Pneumatic motor does not turn, or only slowly.	Compressed air supply is switched off.	Switch on compressed air supply.
	Compressed air supply is paused.	Localize and eliminate compressed air interruption.
	Throttle valve is not opened.	Turn on the throttle valve slowly.
	Throttle valve is defective.	Replace throttle valve ↪ 9.4.3 "Replace throttle valve".
	Pneumatic motor has no lubrication or is running dry.	Lubricate pneumatic motor ↪ 8.4 "Lubrication".
	Pneumatic motor is defective.	Send in pneumatic motor for repairs or replace it ↪ 9.4.4 "Replace pneumatic motor".
	Compressed air hose with cross section less than DN 8 is used.	Assemble compressed air hose with the required diameter. ↪ 11.2 "Connections"
Agitator vibrates or does not run smoothly.	Agitator shaft or agitator blade is not correctly assembled.	<ul style="list-style-type: none"> ▪ Assemble agitator shaft again ↪ 9.4.2 "Replace agitator shaft". ▪ Assemble agitator blade again ↪ 9.4.1 "Replace agitator blade".
	Agitator blade is damaged or bent.	Replace agitator blade ↪ 9.4.1 "Replace agitator blade".
	Agitator shaft has an imbalance or is damaged.	Replace agitator shaft ↪ 9.4.2 "Replace agitator shaft".
Material sprays out.	Material is being agitated at too high a rotational speed.	Reduce rotational speed ↪ 6.4 "Agitate".
Material coat is uneven.	Material is being agitated with too high a rotational speed.	Reduce rotational speed ↪ 6.4 "Agitate".

9.4 Troubleshooting

9.4.1 Replace agitator blade

Check components for damage before assembly. If necessary, replace with new components.

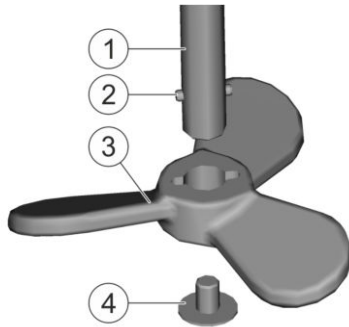

Fig. 14: Replace agitator

Personnel:

- Mechanic

Protective equipment:

- Protective workwear
- Protective gloves
- Safety boots
- Eye protection

Requirements:

- Compressed air hose is disassembled.
 - ↳ 10.2 “Disassemble compressed air hose”
- Throttle valve is closed.

Disassembly

1. Remove screw (4).
2. Remove agitator blade (3).
 - ⇒ Contaminants can stick agitator blades together.

! NOTICE!

Property damage due to disassembly of the agitator blade

If components are stuck together due to contamination, the agitator shaft and the agitator blade may bent during the disassembly of the agitator blade.

- Knock off agitator blade carefully using a rubber mallet.

3. Pull off pin (2) from the agitator shaft (1).

Assembly

4. Insert pin (2) into agitator shaft (1).
5. Insert new agitator blade (3) on the agitator shaft (1).
 - ⇒ The pin (2) rests in the groove of the agitator blade.
6. Screw-in and tighten screw (4).
 - ⇒ Agitator blade has been assembled.

9.4.2 Replace agitator shaft

Check components for damage before assembly. If necessary, replace with new components.

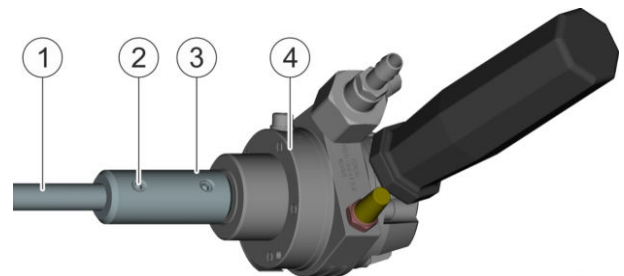

Fig. 15: Replace agitator shaft

Personnel:

- Mechanic

Protective equipment:

- Protective gloves
- Safety boots
- Eye protection

Requirements:

- Compressed air hose is disassembled.
 - ↳ 10.2 “Disassemble compressed air hose”

Disassembly

1. Disassemble agitator blade ↳ 9.4.1 “Replace agitator blade”.
2. Clamp agitator shaft (1) in a vise with plastic protective jaws.
 - ⇒ The pneumatic motor (4) is clamped in a horizontal position.
3. Unscrew threaded pin (2).

4. Pull off pneumatic motor (4) with the connecting piece (3) from the agitator shaft (1).
⇒ Agitator shaft has been disassembled.

! NOTICE!

Material damage due to disassembly of the agitator shaft

If components are stuck due to dirt, that could cause damage to the pneumatic motor and agitator shaft during disassembly of the agitator shaft.

- Do not hit on pneumatic motor.
- Knock off agitator shaft carefully using a rubber mallet.

Assembly

5. Clamp agitator shaft (1) in a vise with plastic protective jaws.
⇒ The pneumatic motor (4) is clamped in a horizontal position.
6. Set pneumatic motor (4) with the connecting piece (3) on the agitator shaft (1). See that the flattened side of the agitator shaft points to the holes for the threaded pin.
7. Screw-in and tighten threaded pin (2).
8. Assemble agitator blade ↪ 9.4.1 "Replace agitator blade".
⇒ Agitator shaft has been assembled.

9.4.3 Replace throttle valve

Check components for damage before assembly. If necessary, replace with new components.

Personnel:

- Mechanic

Protective equipment:

- Protective gloves
- Safety boots
- Eye protection

Requirements:

- Compressed air hose is disassembled.
↪ 10.2 "Disassemble compressed air hose"
- Throttle valve is closed.

Disassembly

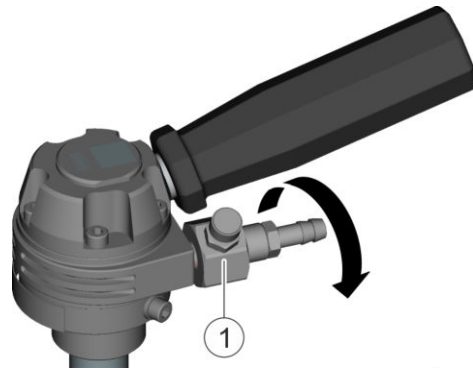

Fig. 16: Disassemble throttle valve

1. Unscrew throttle valve (1) as indicated by the arrow, using a wrench.
⇒ Throttle valve is disassembled.

2. Clean external threads.

Assembly

! NOTICE!

Contamination

If you use a sealing tape, frayed threads from the sealing tape and damage the product.

- Only use thread seal.

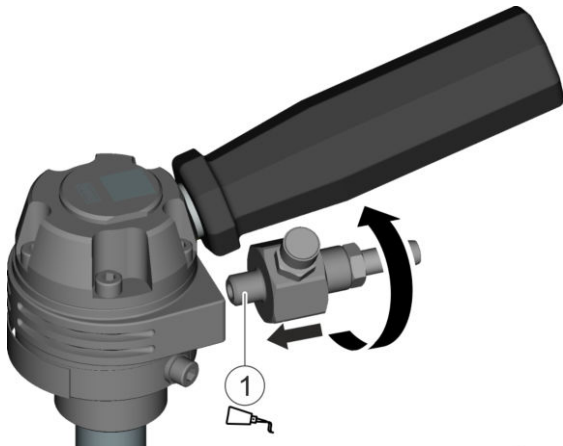

Fig. 17: Assemble throttle valve

Thread seal Loctite 511

3. Apply thread seal on the external threads (1) of the throttle valve.
4. Screw in throttle valve. Make sure that a distance of 3 to 5mm is maintained between nut and motor.
⇒ Adjusting screw points upward.

Throttle valve has been assembled.

9.4.4 Replace pneumatic motor.

Check components for damage before assembly. If necessary, replace with new components.

Personnel:

- Mechanic

Protective equipment:

- Protective gloves
- Safety boots
- Eye protection

Requirements:

- Ground conductor and compressed air hose are disassembled.

- ↳ 10 “Disassembly and Disposal”
- Throttle valve is closed.

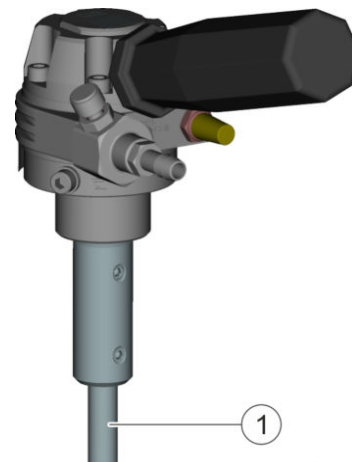

Fig. 18: Replace pneumatic motor

Disassembly

1. Disassemble agitator shaft ↳ 9.4.2 “Replace agitator shaft”.

Assembly

2. Assemble agitator shaft ↳ 9.4.2 “Replace agitator shaft”.

9.5 After troubleshooting

- Connect compressed air supply.
↳ 5.3 “Assemble the compressed air hose”
- If the agitator is used in an EX zone, check grounding for correct connection.
↳ 5.2 “Ground agitator”

10 Disassembly and Disposal

10.1 Safety recommendations

! WARNING!

Escaping compressed air

Compressed air hoses may rupture if under pressure. Escaping compressed air can cause serious injury.

- Disconnect the product from the compressed air supply after the end of working hours.
- Observe the service life of the compressed air hoses. Replace outdated compressed air hoses.

10.2 Disassemble compressed air hose

Personnel:

- Mechanic
- + additional qualification explosion protection

Protective equipment:

- Eye protection
- Protective gloves
- Safety boots

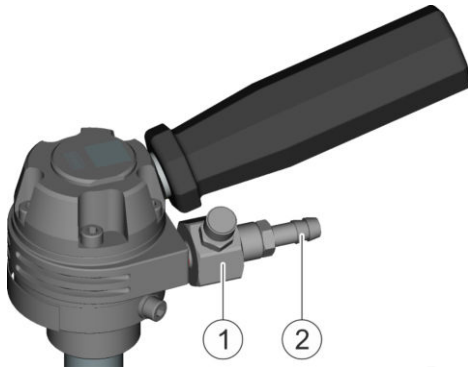

Fig. 19: Disassemble compressed air hose

Requirements:

- Atmosphere is not explosive.
- Compressed air supply is switched off.
- Lines are depressurized.
- Throttle valve is closed.

1. Open the hose clamp at the throttle valve (1).
2. Pull out the compressed air hose from the nozzle (2).

10.3 Disassemble ground conductor

Personnel:

- Electrician
- + additional qualification explosion protection

Protective equipment:

- Protective gloves
- Anti-Static Safety Boots

Requirements:

- Atmosphere is not explosive.

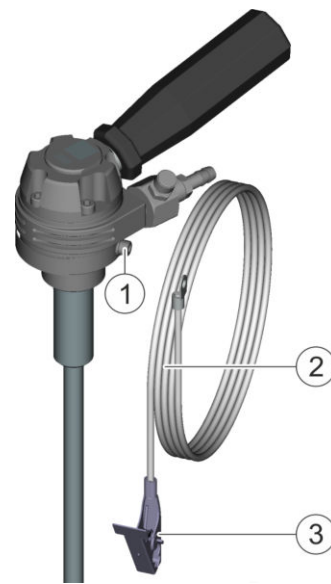

Fig. 20: Grounding

1. Unscrew screw (1).
2. Remove ground conductor (2).
3. Disassemble terminal (3) of the ground conductor from the current conductor.
4. Insert the screw (1) again and tighten it.

10.4 Disposal

ENVIRONMENT!

Improper waste disposal

Improper waste disposal threatens the environment and prevents re-use and recycling.

- Clean components before their disposal.
- Always dispose of components in accordance with their characteristics.
 - ↳ 11.8 "Materials used"
- Collect leaked out utilities and auxiliaries completely.
- Dispose of work equipment soaked in coating materials or operating substances according to the disposal provisions in force.
- Dispose of utilities and auxiliaries according to the disposal provisions in force.
- In case of doubt, refer to the local disposal authorities.

11 Technical data

11.1 Dimensions and weight

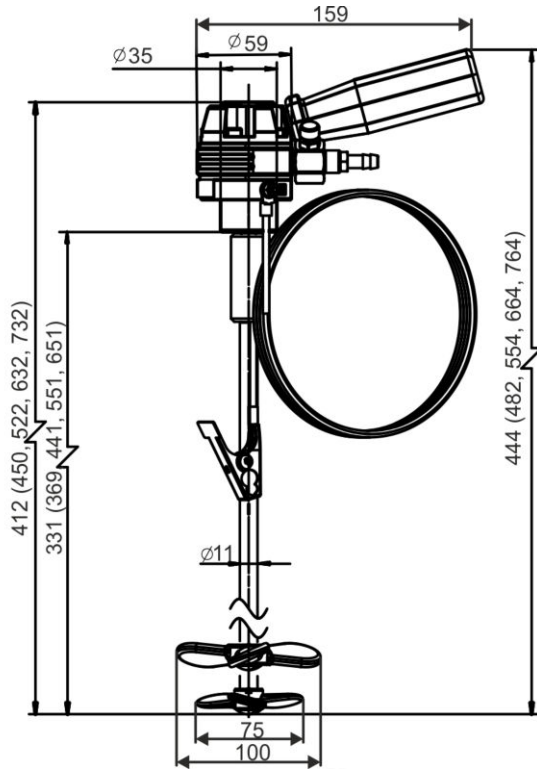

Fig. 21: Dimensions

Detail	Value
Length	approx. 444-764mm
Width	approx. 159 mm
Depth	75-100mm
Agitator shaft incl. connecting piece	330, 369, 440, 550, 650mm
Weight	from 1.5kg
Agitator blade diameter	75, 100mm

11.2 Connections

Detail	Value
Compressed air connection	DN 8mm
Ground conductor	min. 4 mm ²
Cable lug	10 x 5

11.3 Operating conditions

Detail	Value
Surface temperature when operating with protective gloves, max.	40°C
Surface temperature when operating with heat-resistant protective gloves, max.	85°C
Material temperature, max.	40°C
Ambient temperature	0°C – 40°C
Distance of the agitator blade from the wall and the bottom of the container, min.	25mm
Distance pneumatic motor to container edge, min.	200 mm

11.4 Emissions

Detail	Value
Noise level at 900 RPM	87 dB(A)

11.5 Operating values

Detail	Value
Protection type	IP65
Operating pressure, min.	0.5 bar
Operating pressure, max.	7 bar
Ventilation duration of the pneumatic motor, max.	2 s
Grounding resistance	<2 Ω
Recommended rotational speed range	up to 800 RPM
Power	0.07kW

Air consumption

The characteristic curve shows the dependence between the air consumption and the speed of the agitator.

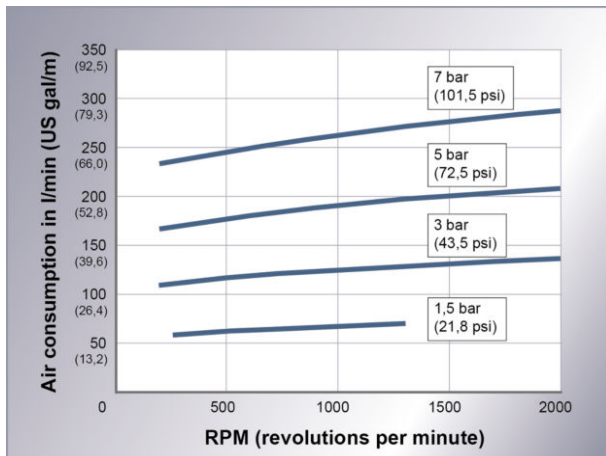

Fig. 22: Characteristic curve agitator blade Ø100

11.6 Compressed air quality

Purity classes in accordance with ISO 8573-1: 1:4:1

11.7 Type plate

The type plate is placed on the pneumatic motor and features the following details:

- Product name
- Material number
- Year of manufacture
- Serial number
- Maximum operating pressure
- CE labeling
- Ex labeling

11.8 Materials used

All parts in contact with material are made of stainless steel

Component	Material
Agitator	1.4308
Agitator lens flange head screw	1.4310
Threaded pins on the connecting piece	1.4310
Connecting piece	1.4305
Agitator shaft	1.4305
Agitator cylinder pin	1.4305

11.9 Operating and auxiliary materials

Material	Material number
Thread seal Loctite 511	--
Lubricant VG 32 0.2l	W32020045

11.10 Material specification

Suitable Material:

- Flammable fluid coating materials and their cleaning media
- Non-flammable fluid coating materials and their cleaning media

Conductivity

Detail	Value
Conductivity, min.	10000pS/m

12 Spare parts, tools and accessories

12.1 Spare parts



Fig. 23: Spare parts

Item	Denomination	Amount	Material number
1	Compressed air connection DN 8 Js 8	1	
2	Throttle valve	1	M54680026
3	Noise muffler G 1/8"	1	M54610077
4	Threaded pin M6 x 6	2	
5	Connecting piece	1	
6	Agitator shaft 330mm (only for N68040616, N68040621)	1	M04080848
	Agitator shaft 369mm (only for N68040617)	1	M04080861
	Agitator shaft 440mm (only for N68040618, N68040622, N68040625)	1	M04080849
	Agitator shaft 550mm (only for N68040619, N68040623)	1	M04080850
	Agitator shaft 650mm (only for N68040620, N68040624)	1	M04080851
7	Lens flange head screw M6 x 8	1	Included in M41990010
8	Agitator blade Ø75mm (only for N68040616-N68040620 and N68040625)	1	M04620008
	Agitator blade Ø100mm (only for N68040621-N68040624)	1	M04620009
9	Cylinder pin M 3 x 14	1	Included in M41990010
10	Pneumatic motor	1	N04390007

12.2 Accessories

Denomination	Material number
Stand for Agitator shaft length 330 mm and 369 mm	N25220010
Stands for agitator shaft 440mm/550mm/650mm	N25220011
Ground conductor length 5 m, cable lug 10mm x 5mm	E04030004
Agitator screw set: <ul style="list-style-type: none"> ▪ Lens flange head screw M6 x 8 ▪ Cylinder pin M 3 x 14 	M41990010

12.3 Order

 **WARNING!**

Unsuitable spare parts in explosive areas

Spare parts not compliant with the specifications of the ATEX directives can cause explosions in an explosive atmosphere. Serious injury and death could be the consequence.

- Use exclusively original spare parts.

 **WARNING!**

Unsuitable spare parts

Spare parts of third-party suppliers may possibly not be able to hold the loads. Serious injury and death could be the consequence.

- Use exclusively original spare parts.

Ordering spare parts, tools and accessories as well as information on products that are listed without order number → "Hotline and Contact".

13 INDEX

A	
Accessories	28
Advanced training	7
Agitating	13
Agitator	
assembly	21
disassembly	21
grounding	10
operation	13
replacement	21
Agitator shaft	
assembly	21
disassembly	21
replacement	21
B	
Brief description	4
C	
Checks	
Operation	12
Cleaning	15
Cleaning bath	16
Cleaning container	15
manual	15
Compressed air hose	
assembly	10
disassembly	24
Compressed air quality	26
Conductivity	26
Connections	25
Construction	8
Contact	2
D	
Defects Table	20
Dimensions	25
Disposal	24
E	
Emissions	25
Ex protection	
Ex labeling	4
F	
Fault	
Behavior in the event of faults	20
Function	8
G	
General notes	
Operation	12
Ground conductor	
disassembly	24
Grounding	10
H	
Hotline	2
I	
Incorrect use	4
Information about the document	2
L	
Lubricant	26
Lubrication	18
Lubrication schedule	18
M	
Maintenance schedule	18
Material number	2
Material specification	26
N	
Notes	
Representation	4
O	
Operating conditions	25
Order	28
Overview	4
P	
Personal protective equipment	7
Pneumatic motor	
assembly	23
disassembly	23
lubrication	18
replacement	23
Power values	25
Property damage	6
Protective equipment	7
Electrostatic discharge	7
Q	
Qualification	7
Qualification of the personnel	7
R	
Representation	
Notes	4
Residual risks	6
S	
Safety	
Notes	4
Property damage	6
Residual risks	6

Safety notes		materials used	26
Disassembly	23	Operating conditions	25
Maintenance	17	Power values	25
Safety notices		Weight	25
Cleaning	14, 17	Technical Data	
Operation	11	Connections	20
Troubleshooting	19	Throttle valve	
Scope of Supply	9	assembly	22
Scope of the document	2	disassembly	22
Sealant	26	Replace	22
Service	2	Training	7
Spare parts	27	Transport inspection	8
Stand		Transporting	8
assembly	9	Type plate	26
Storage	9	U	
T		Unpacking	8
Technical data		Use	4
Compressed air quality	26	W	
Dimensions	25	Weight	25
Emissions	25	Wrong use	4
Material specification	26		



LEADING IN
PRODUCTION
EFFICIENCY

 Dürr Systems AG
Application Technology
Carl-Benz-Str. 34
74321 Bietigheim-Bissingen
Germany

 Phone +49 7142 78-0

 www.durr.com

Translation of the original operation manual
MAG00007EN, V01

The distribution and reproduction of this document as well as the use and communication of its contents are not permitted without express written approval. Offenders will be liable for damages. All rights reserved in the event of the patent grant or registry of a utility model.

© Dürr Systems AG 2022